

Model-based Software Engineering

(02341, spring 2017)

Ekkart Kindler

DTU Compute

Department of Applied Mathematics and Computer Science

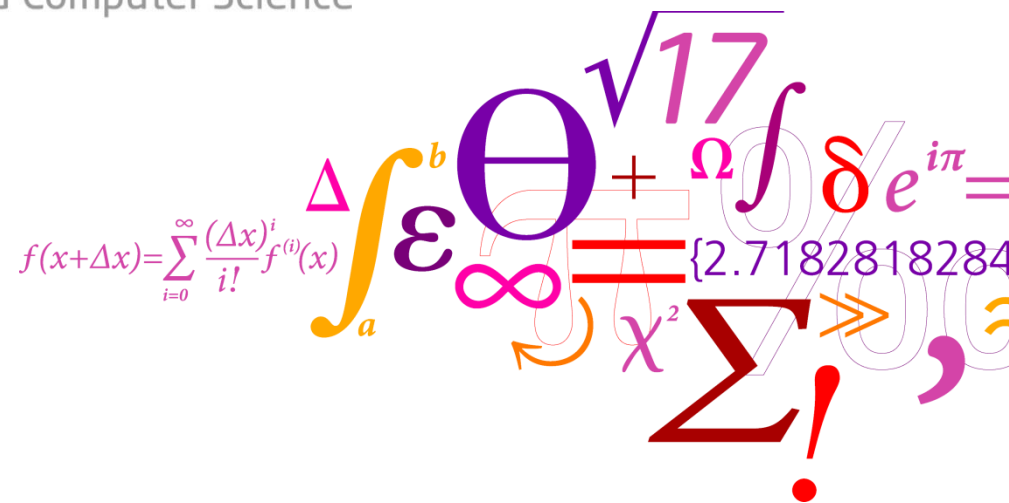

IV. Business processes & (Workflow Management)

DTU Compute

Department of Applied Mathematics and Computer Science

Again we just scratch the surface.

Purpose:

- Modelling on domain level
- Basis for project (which is a editor and simulator for **YAWL**)

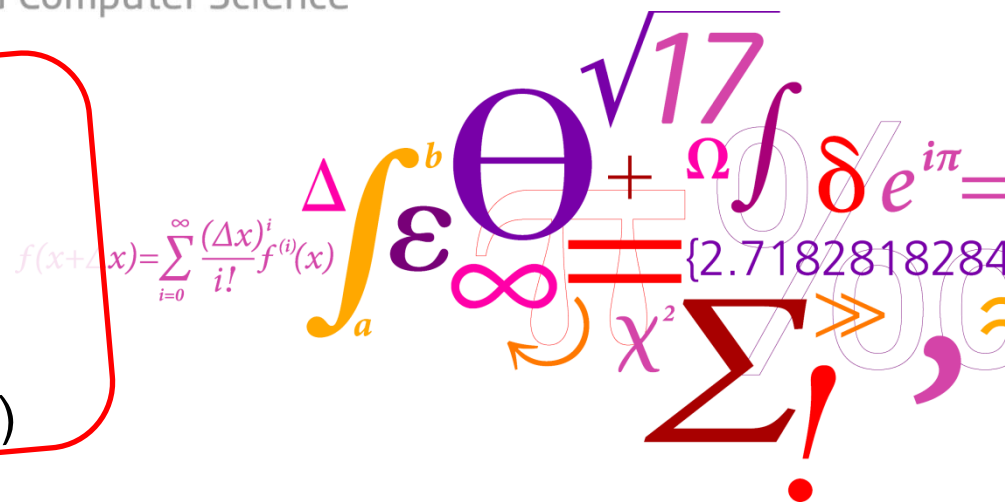

1. Business Processes

A simple example: A business trip (“German version”)

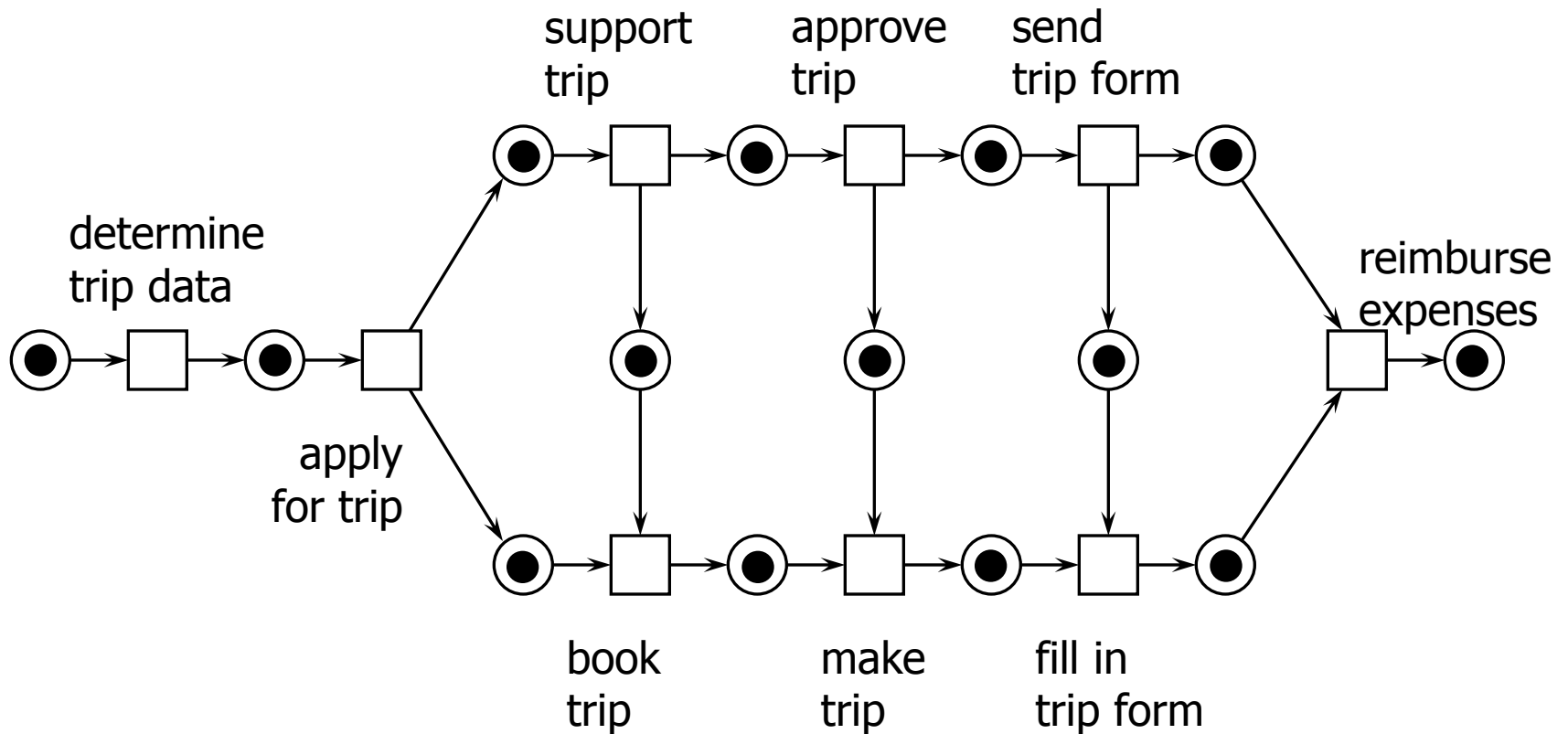

A **business process** consists of a collection of *activities* that are executed in some enterprise or administration according to certain rules and with respect to certain goals.

- Business trip
- Hospital information system
 - Patient registration
 - Special physical examination of a patient
 - Complete stay of a patient
- Facility management
 - apply for the construction of a new building
- Production
 - Air plane construction
- ...

1. Business processes can take quite different time: from a few seconds to several months or even years.

Slogan from transaction theory:
„Workflows are **long-lived transactions**“

2. A business process can be composed from other business processes.

Slogan from transaction theory:
„Workflows are **nested transactions**“

3. The order of activities is fully defined in some examples; in other examples, there is only a vaguely defined order.

In some examples, the order is not defined at all; maybe, not even the possible activities are defined.

Structured / ad hoc / case
handling

Our example revisited

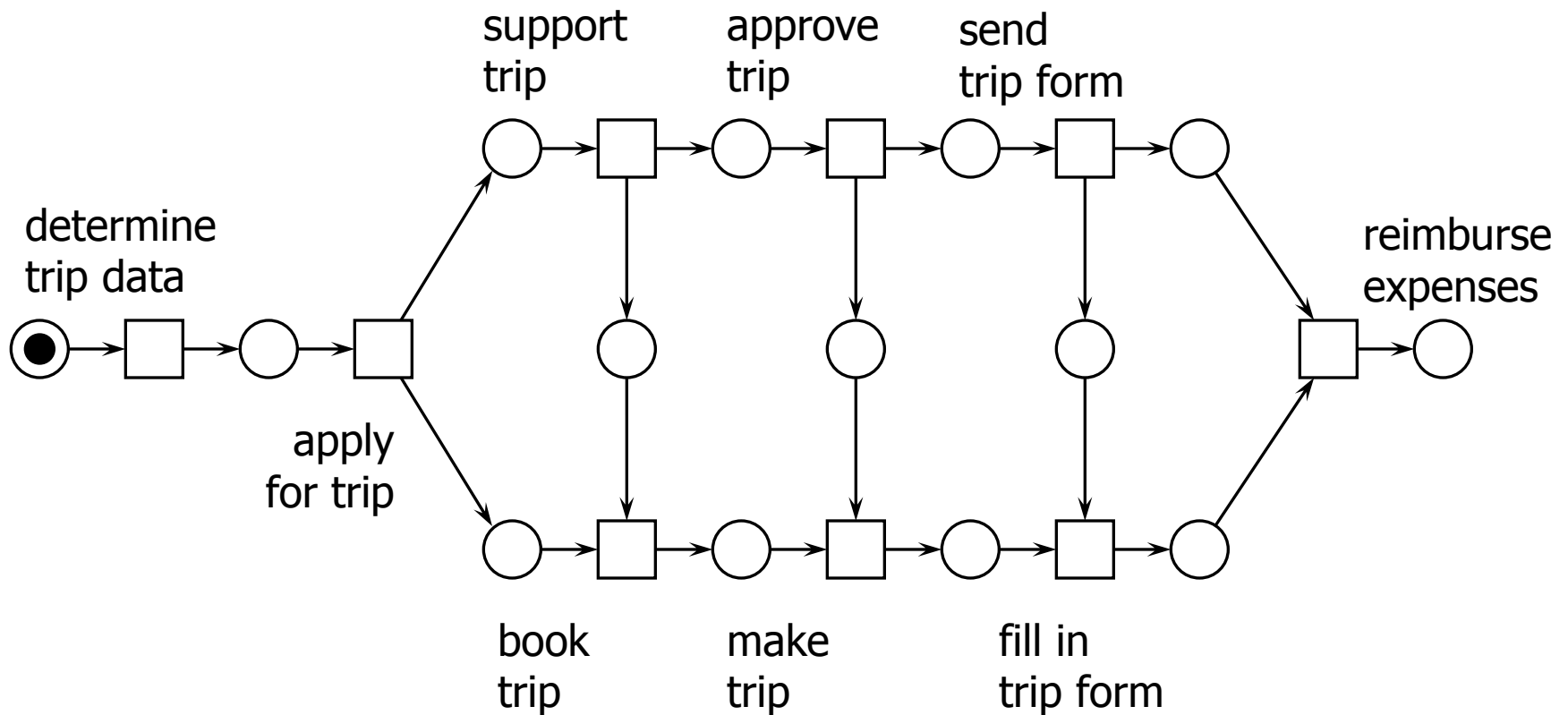



An **task** of a business process is an atomic work step that, on the given level of abstraction, cannot be split into more detailed steps.

NB: „Atomic“ is with respect to some given or chosen level of abstraction.

When the task is executed, we call it activity (instance of a task).

Examples:

- fill in an application form
- support trip (signature of superior)
- send a reminder
- take a blood-sample
- pay out a credit
- ...

4. The level of automation of a task varies:

- Some tasks/activities can be executed **fully automatically**.
- Some tasks/activities can be executed **semi-automatically**.
- Some tasks/activities can be executed **manually** only.

Re: Business Trip

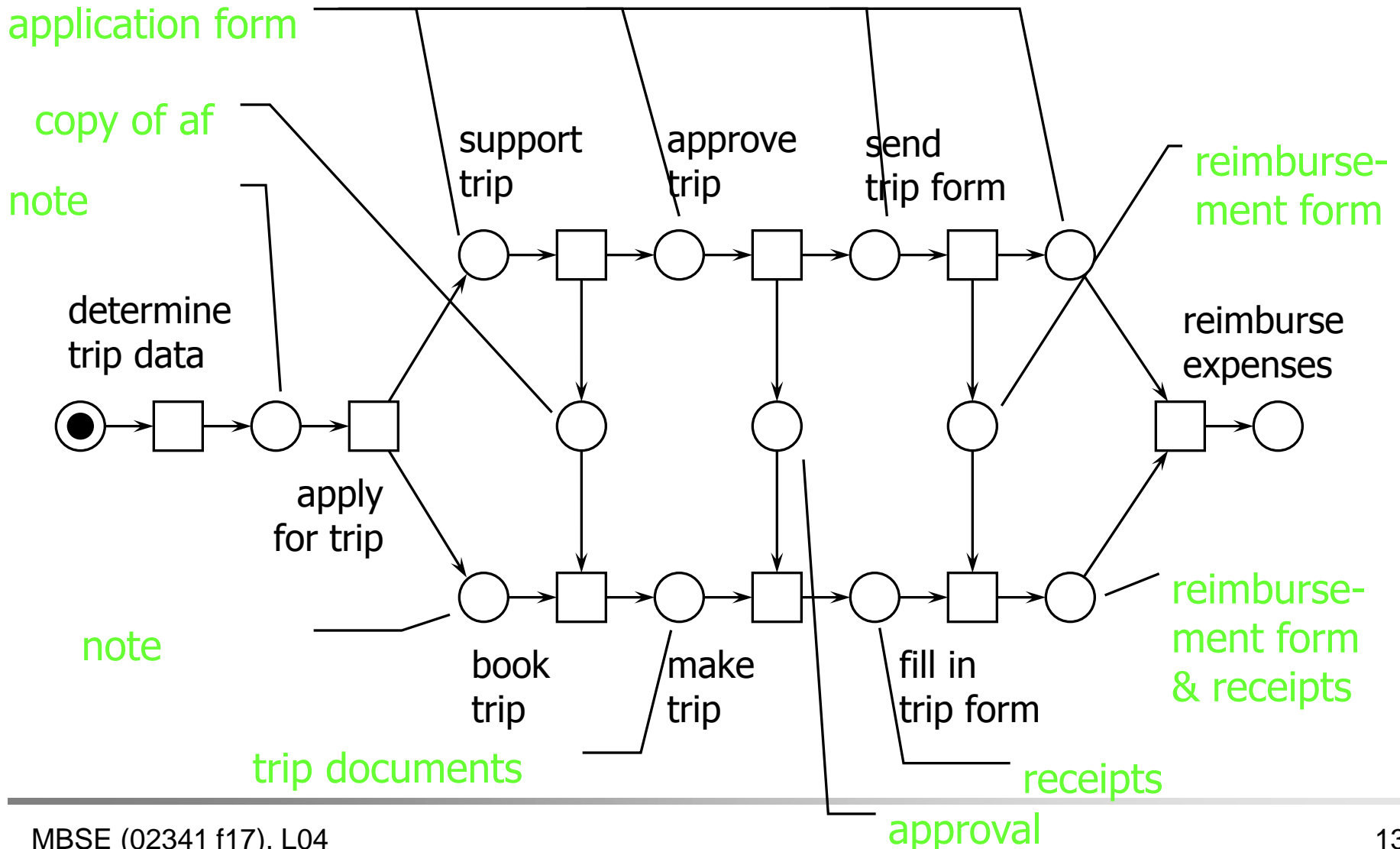

In a business process, **documents** are created, used, and changed.

These documents help to exchange information among different activities of the same business process and among different business processes.

Right now, we ignore the structure of documents (black tokens); but in a more detailed process model, this aspect would need to be modelled too.

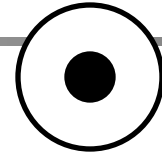

Examples:

- Applications
- Approvals
- Contracts
- Reminders
- Receipts
- Tickets, ...
- Notes

- Documents can be in electronic form or on paper.
- We use documents as a modelling concept; we abstract from its physical representation.

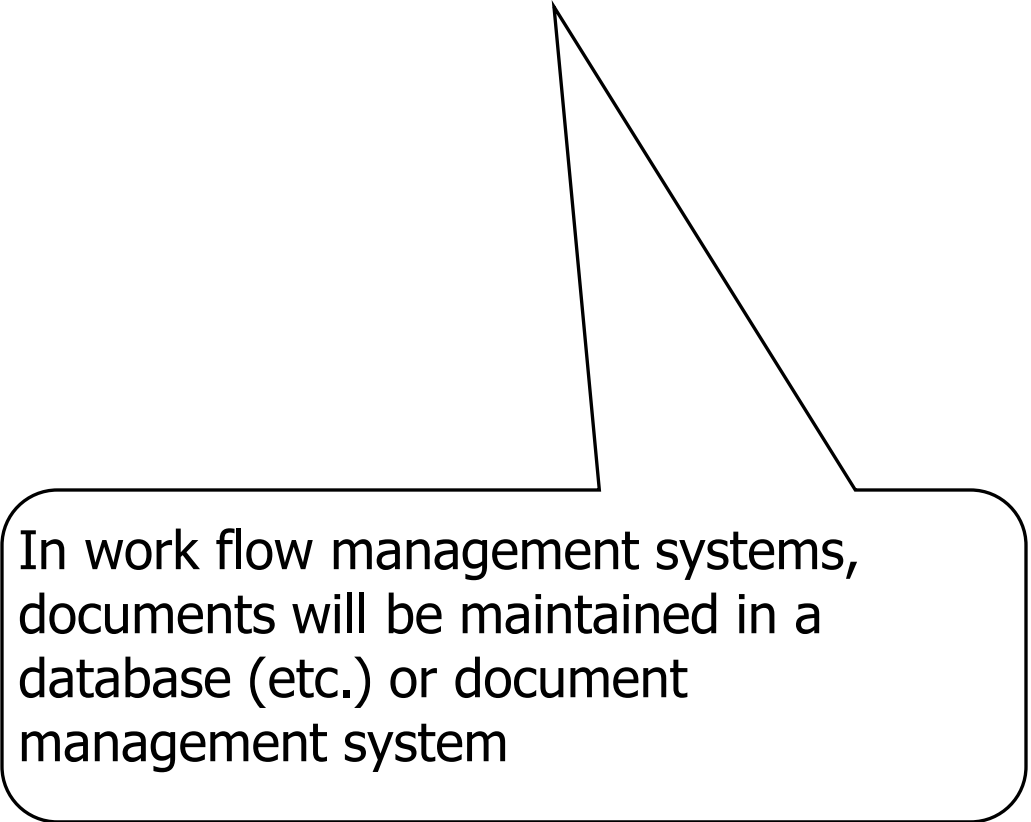

In work flow management systems, documents will be maintained in a database (etc.) or document management system

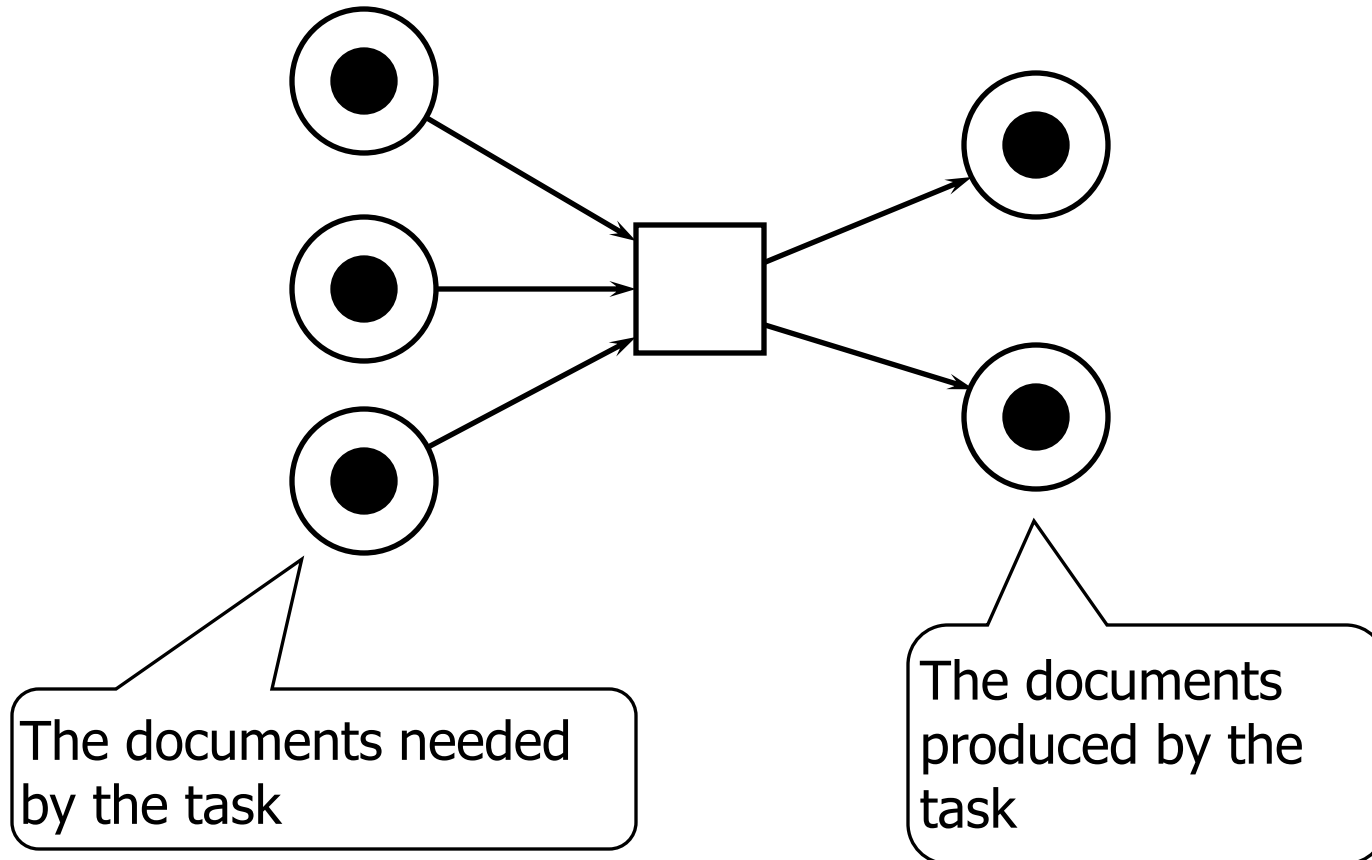

Re: Business Trip

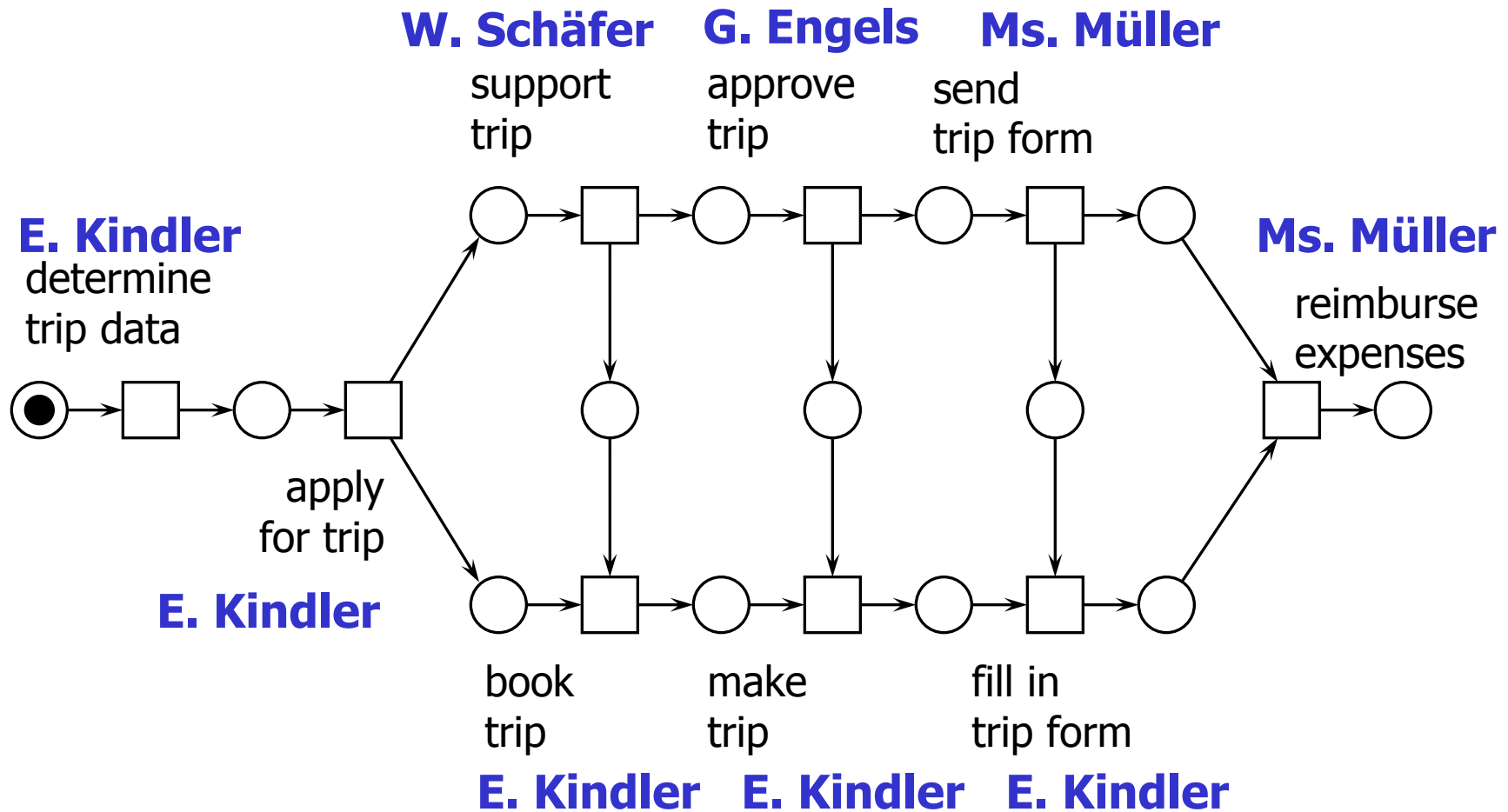

A **resource** is a means necessary for executing an activity.

When the resource is a person, we call the resource an **agent**.

Examples:

- Persons (W. Schäfer, W. Engels, ...)
- Printers
- Computers
- Devices (e.g. for analysing blood)
- ...

- In a concrete instance of a business process, there are concrete resources and agents – keeping track of the involved resources is good for documentation purposes.
- In a model of a business process, concrete resources and concrete agents are problematic (business trip, vacations, sick leave, etc.)

A **role** is the capability (or competence) of an agent or a resource to execute specific activities.

The same resource can have several roles.

Roles can be considered as a classification of resources.

Examples:

- research assistant
- superior
- director
- doctor
- clerk
- head of department
- ...

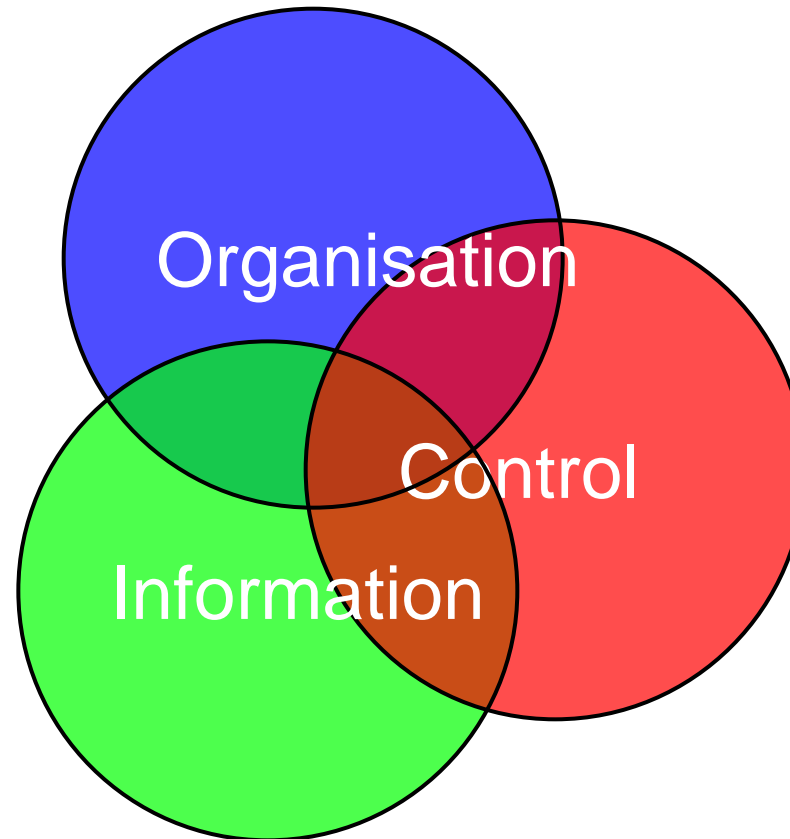

- Causal relation among the activities
(order in which the activities are executed)

- Documents and data and their structure and
- how they are propagated between different activities.

- Agents and resources
- roles and
- how they are needed for tasks

A **Workflow** is the realization of a business process by some information system.

In addition to the aspects of a business process, workflows have more aspects:

- **Operational aspects:**
automation of activities, automatic assignment of activities, support of activities by applications, ...
- **Transactional aspects:**
Consistency, persistence, recovery and role back, ...
- **Technical aspects:**
encodings, database accesses, ...
- ...

An **application** is a program that supports the execution of an activity.

Examples:

- Word processor
- Spread sheet
- Mail reader
- ...

A **Workflow Management System** is an information system for the

- **development,**
- **planning,**
- **control, execution, and monitoring,**
- **documentation and**
- **evaluation**

of workflows (business processes).

Today many information systems (ERP, CRM, ...) have a workflow module integrated.

Measures for achieving these goals:

- **Modelling**
- **Analysis / Simulation**
- **Validation**
- **Restructuring
(Optimisation / Reengineering)**
- **Enactment:**
Execution, monitoring,
controlling, documentation.

Business process
management
(BPM)

Workflow
management
(WfM)

- Agents (employees in their roles)
- Customers (external „users“)
- Managers
 - for a single instance of a business process
 - for all instances of a business process
- Administrators
- Developers (analysts, designers, ...)

Classification (after Leymann/Roller)

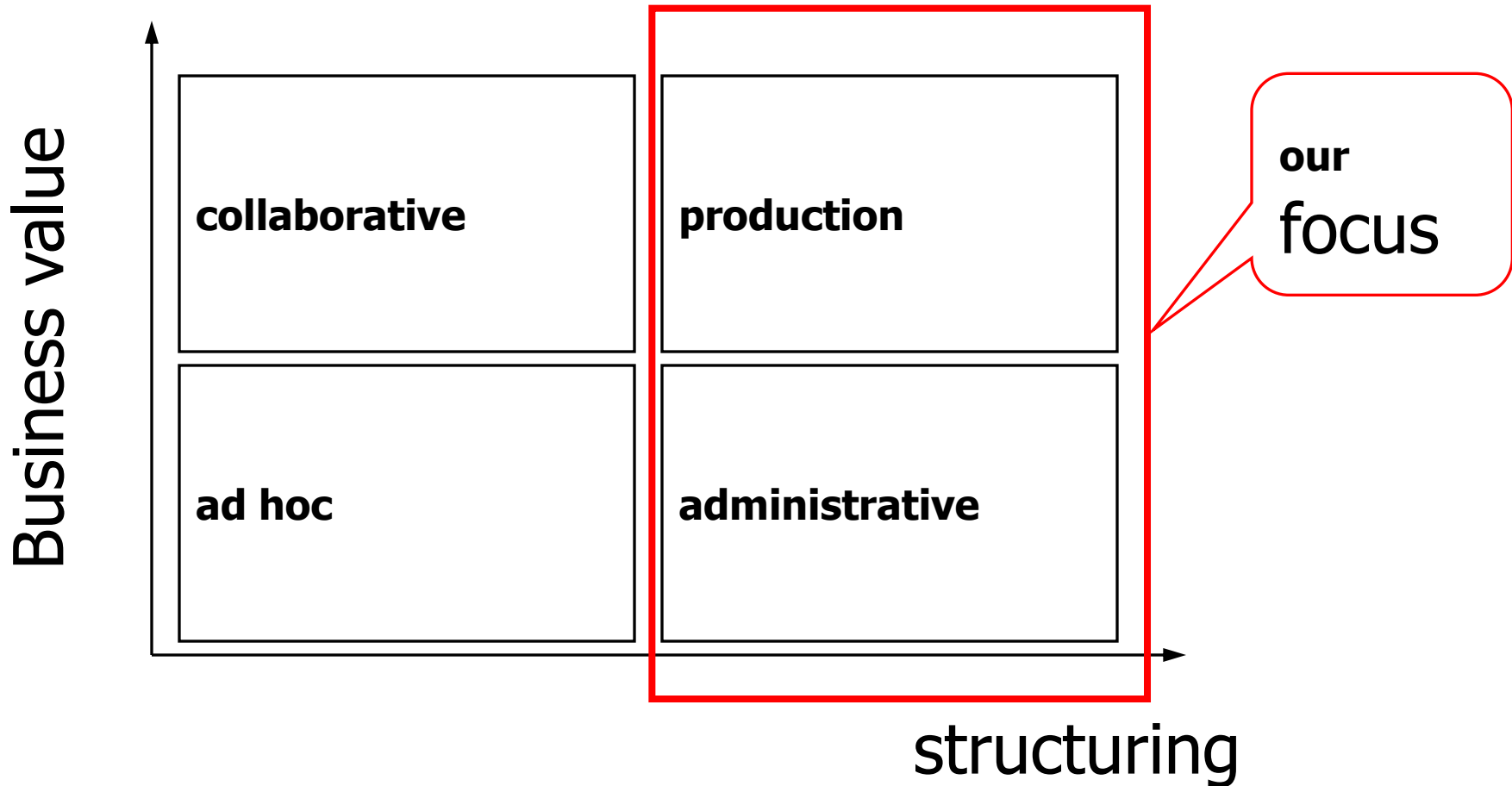

Up to now, we used the same name for two different concepts:

- The execution of a concrete business process (e.g. your trip to Aarhus two weeks ago).
- The general instructions or rules to execute a business process (e.g. for a business trip)

Which should we call a business process?
How should we call the other concept?

- We often call both concepts business process; the difference is clear from the context.

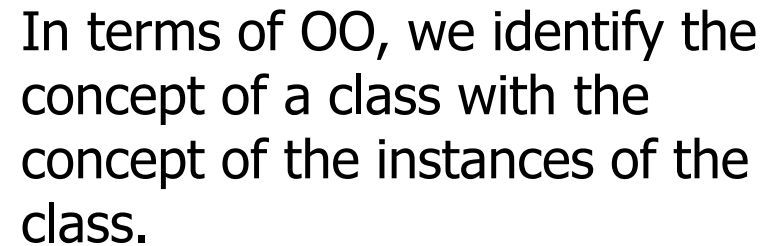

In terms of OO, we identify the concept of a class with the concept of the instances of the class.

- If necessary we talk
 - about an **instance of a business process** or a **case** and
 - about a **model of a business process** or a **process**

In this section, we introduce some additional notation for modelling business processes with Petri nets in a slightly more user friendly way: YAWL* (Yet another Workflow Language)

- XOR-split / XOR-join
- AND-split / AND-join
- OR-split / OR-join
- Reset-arcs

**) A slightly academic workflow notation!*

In your project, you implement a graphical editor and a simulator for YAWL (the subset presented here and in the project slides)

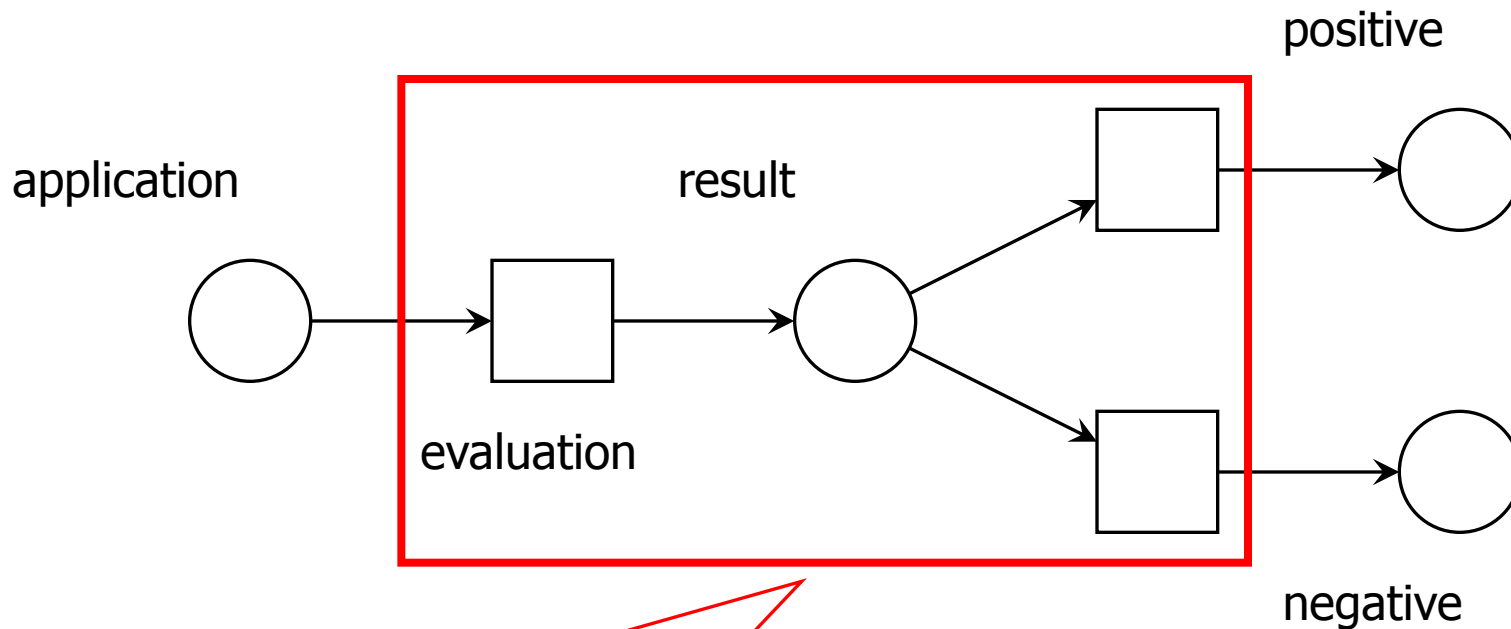

One task: two different outcomes: We would like to consider this as a single activity with two possible outcomes!

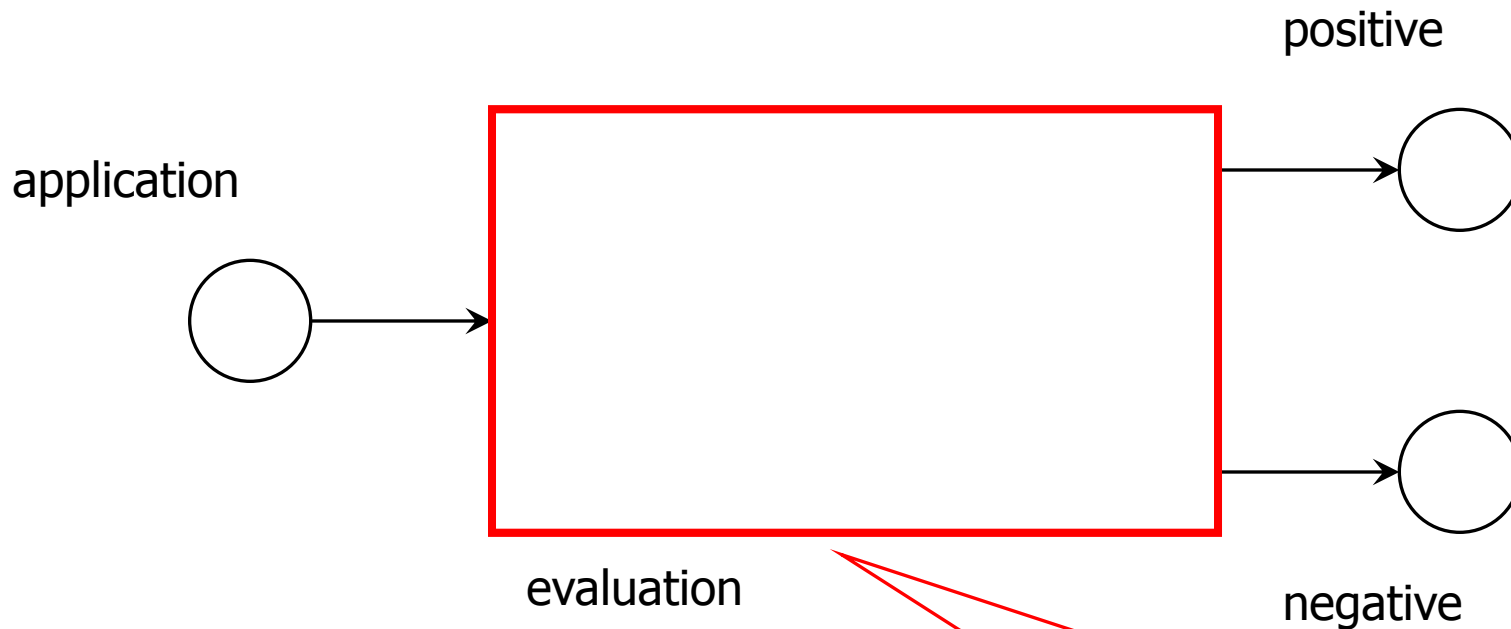

Read as Petrinet, this would be wrong: both places, positive and negative, will be marked!

Solution: Explicit XOR-Split

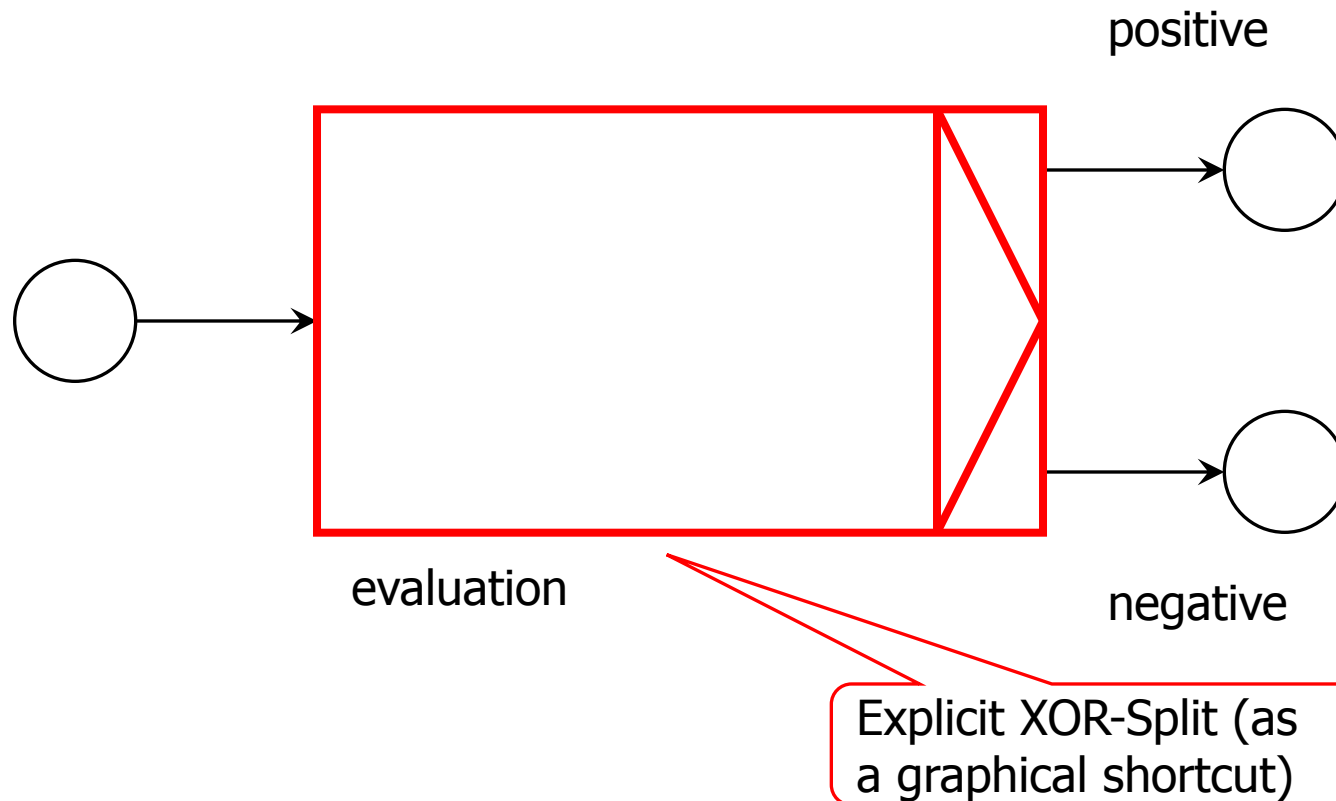

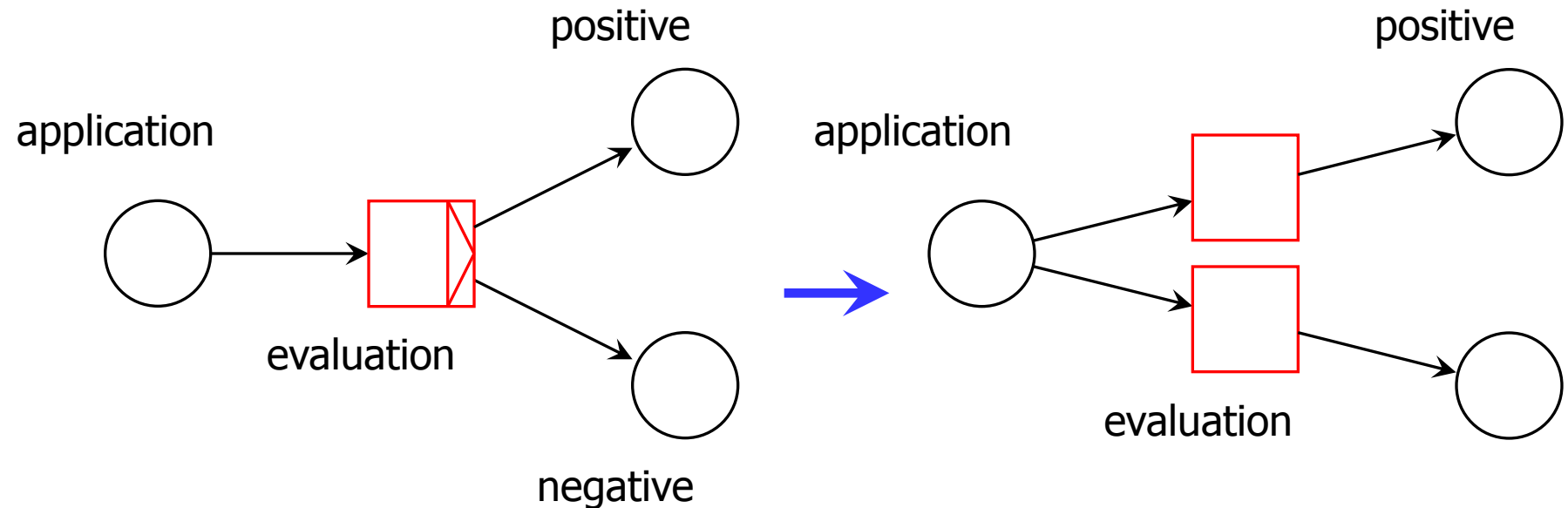

XOR-split

**its Petri net
interpretation**

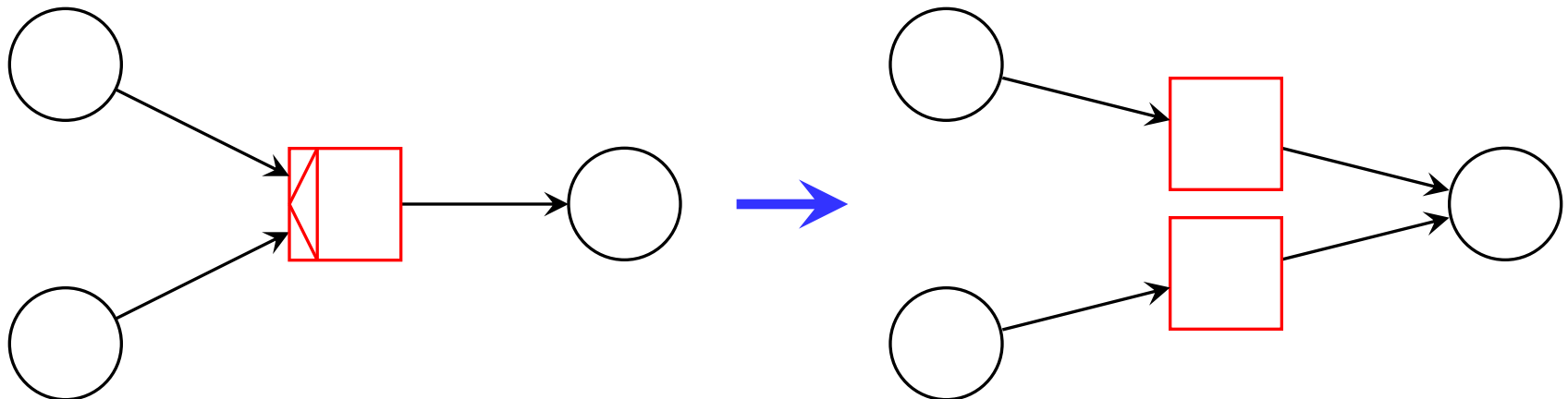

XOR-join

**its Petri net
interpretation**

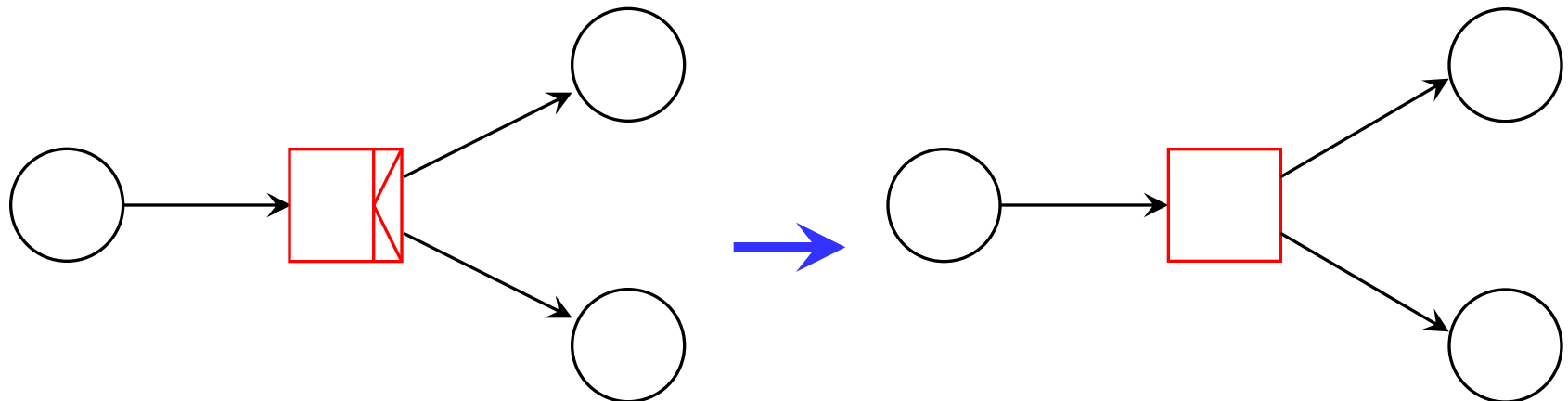

AND-split

**its Petri net
"interpretation";
a transition**

Petri Net Semantics for AND-Join

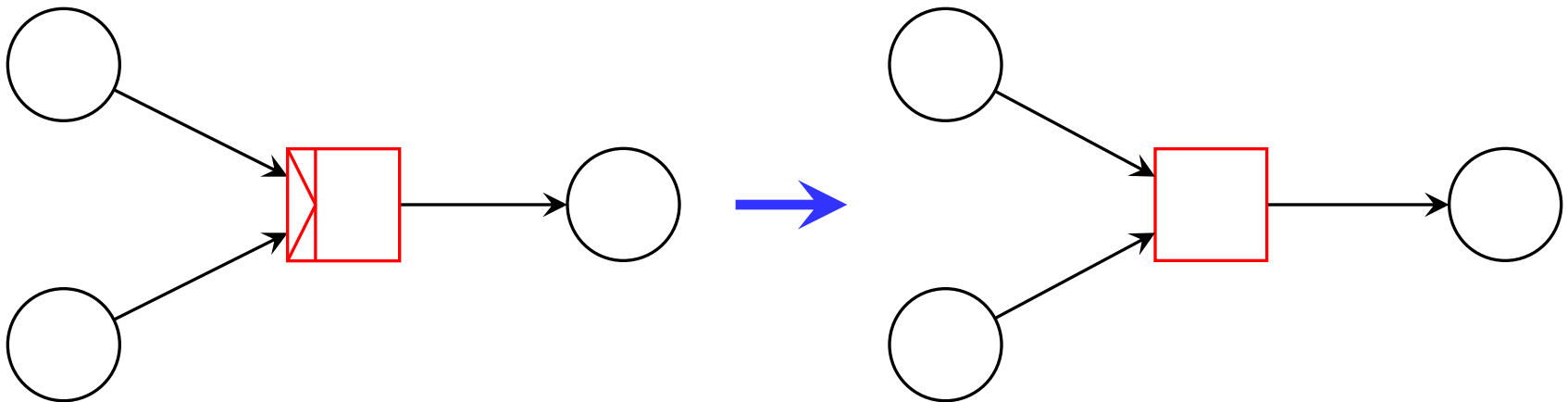

AND-join

**its Petri net
"interpretation";
a transition**

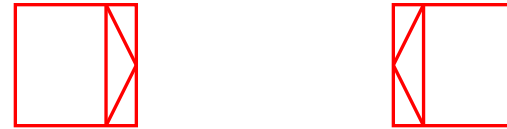

- An XOR-split allows us to model an activity with different outcomes as a single „transition“
- An XOR-join allows us to model an activity with different preconditions as a single „transition“
- XOR-joins and XOR-splits correspond to conditional routing.

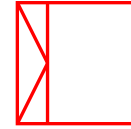
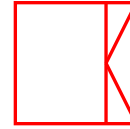

- AND-split and AND-join correspond to the usual Petri net transitions;
- They have been introduced for symmetry reasons only.
- AND-join and AND-splits correspond to parallel routing.

Example: OR-split/join

[from: <http://www.yawlfoundation.org/pages/research/orjoin.html>]

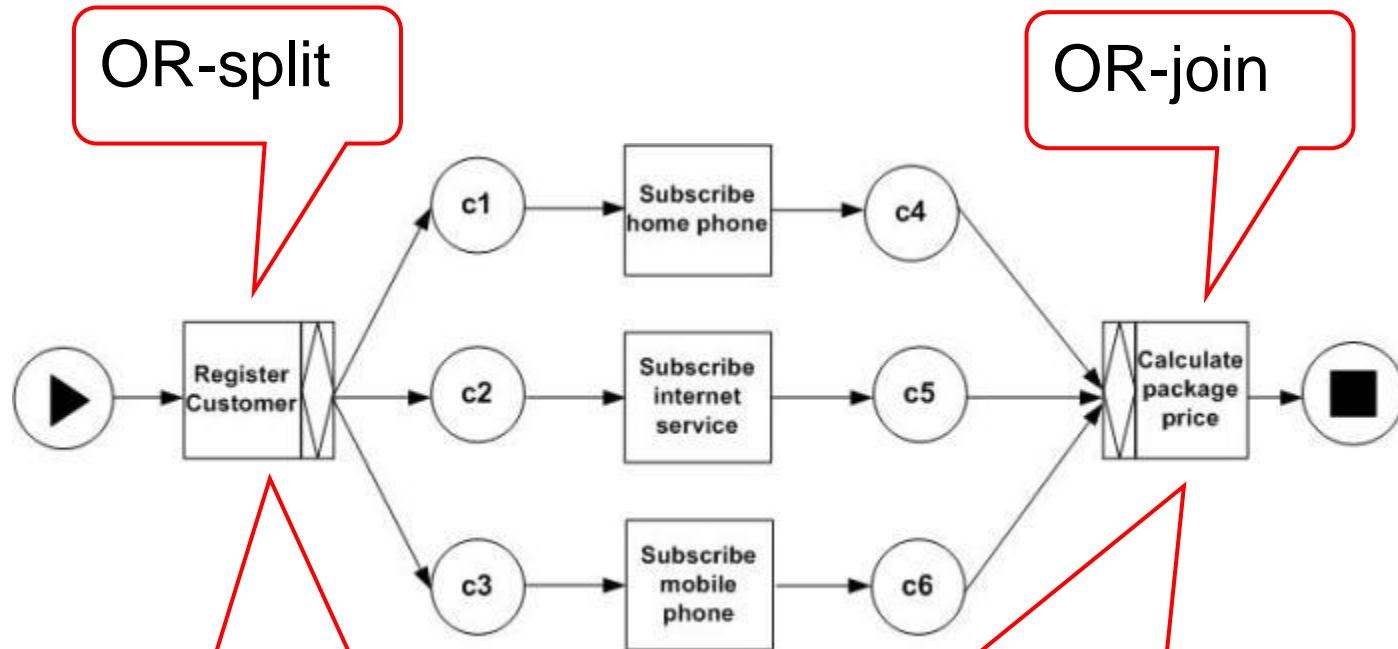

OR-split

OR-join

Adds token to some output places (at least one)

Needs tokens on at least one input place; removes one token for each place that has a token; but → slides 51/52

Example: OR-split/join

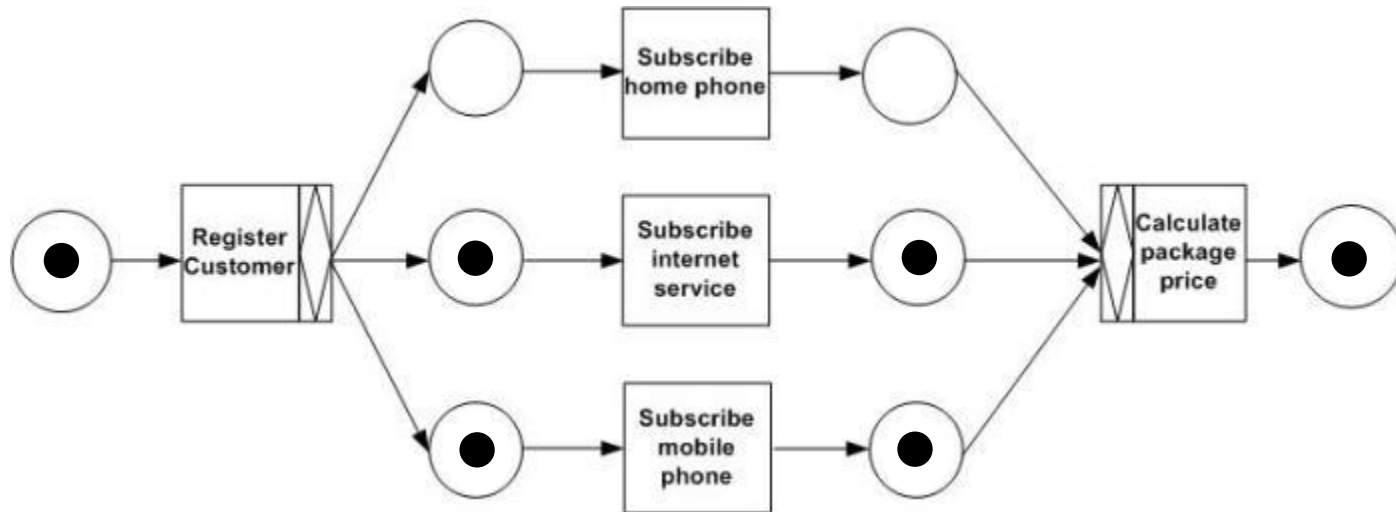

Example: OR-split/join

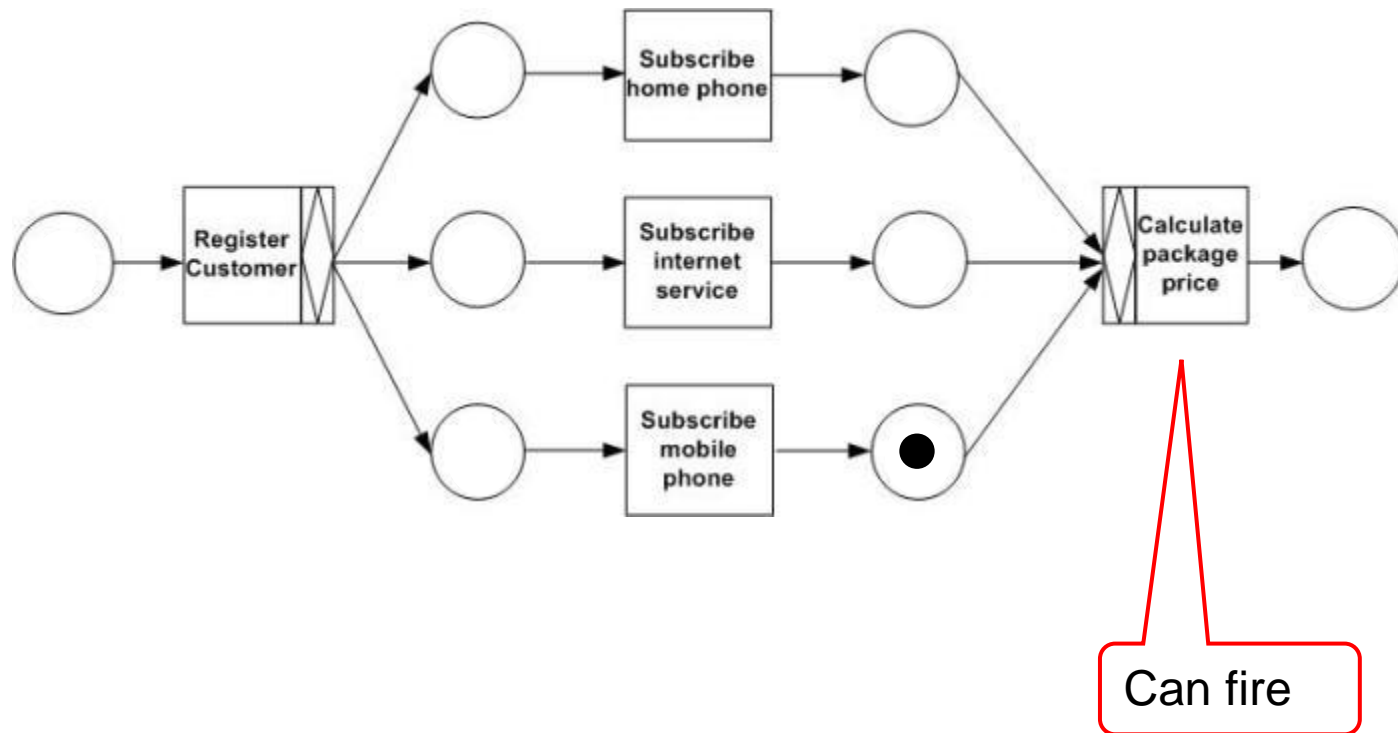

Example: OR-split/join

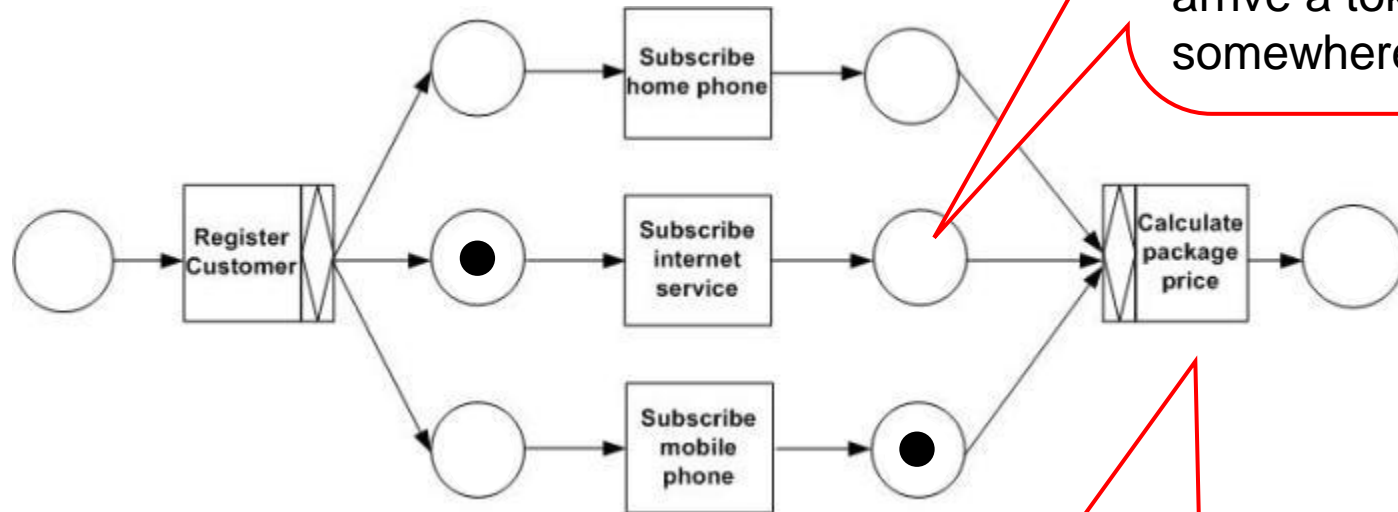

When an input place of an OR-join transition is not marked, the OR-join should not fire, if there still could arrive a token from somewhere!

Cannot fire! The transition should wait until the other token has arrived!

Example: OR-split/join

In complex examples, it is “a bit tricky” to decide whether a token could arrive at some place! But, a warning can be issued when firing the transition, that there is the potential for a token to arrive from somewhere!

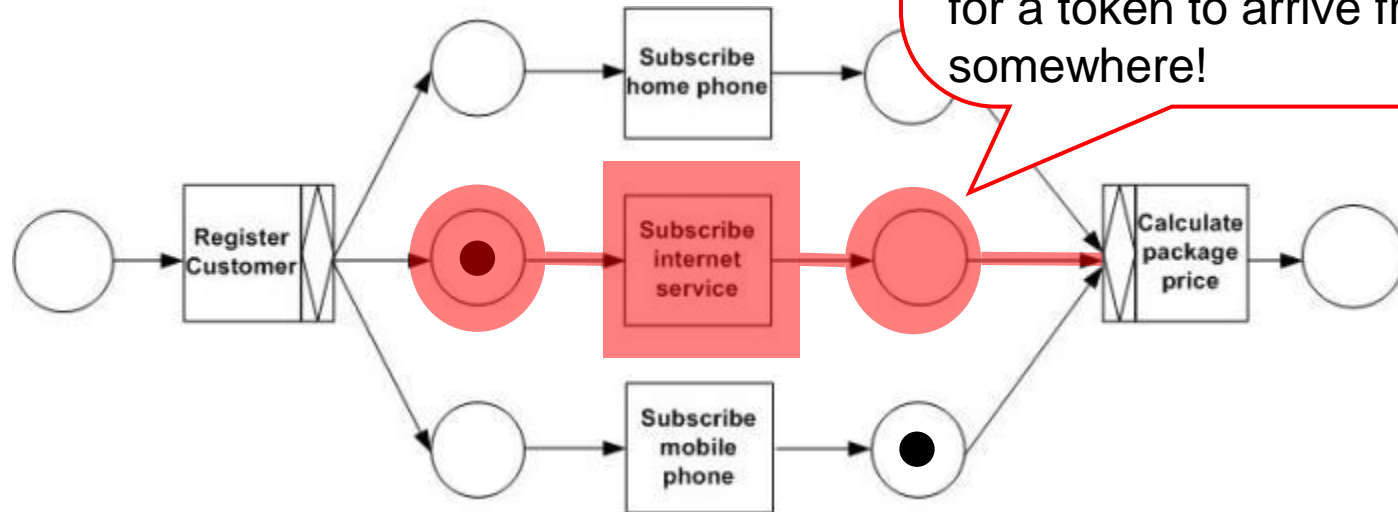

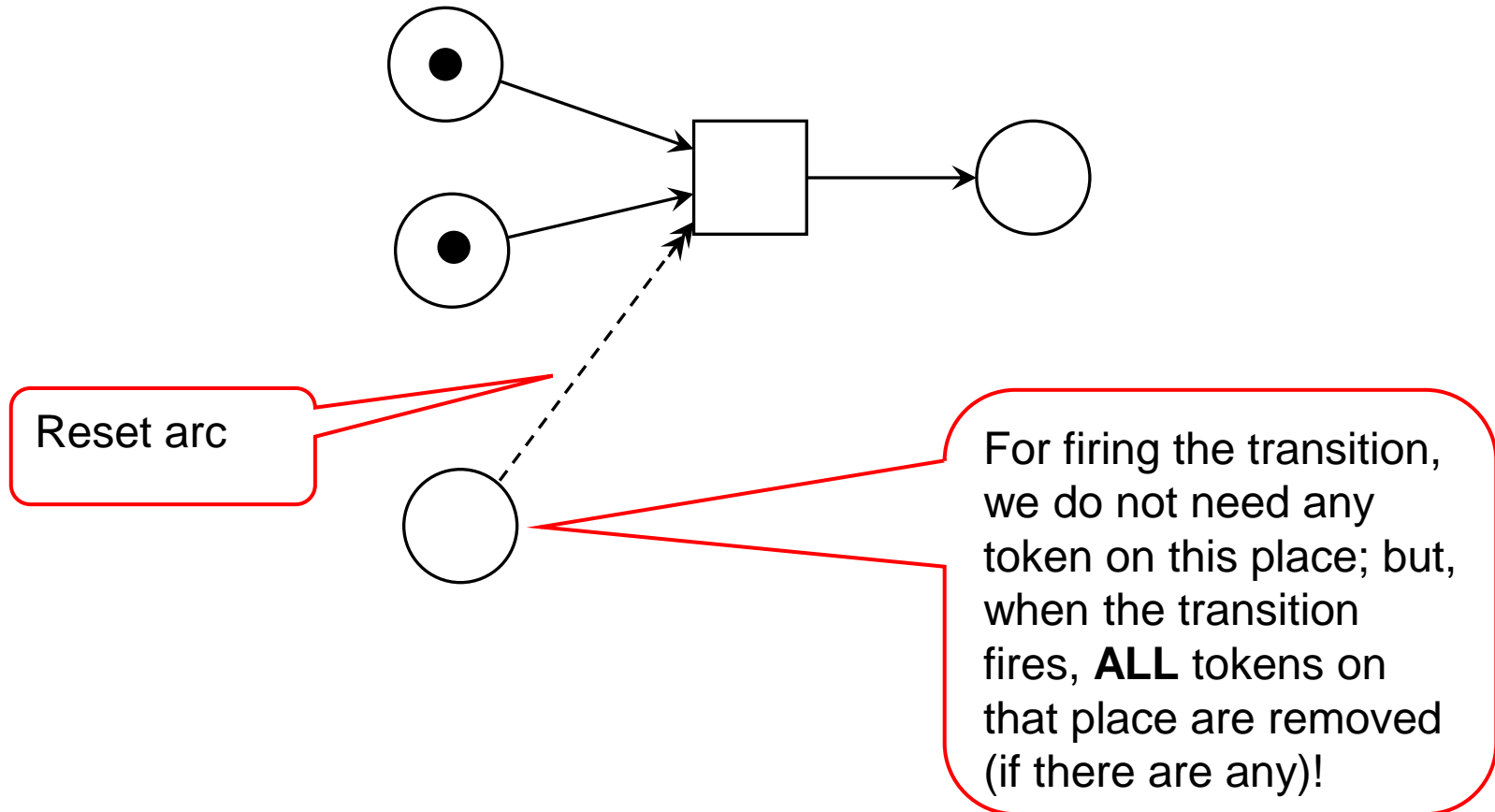

Reset-arcs: Semantics

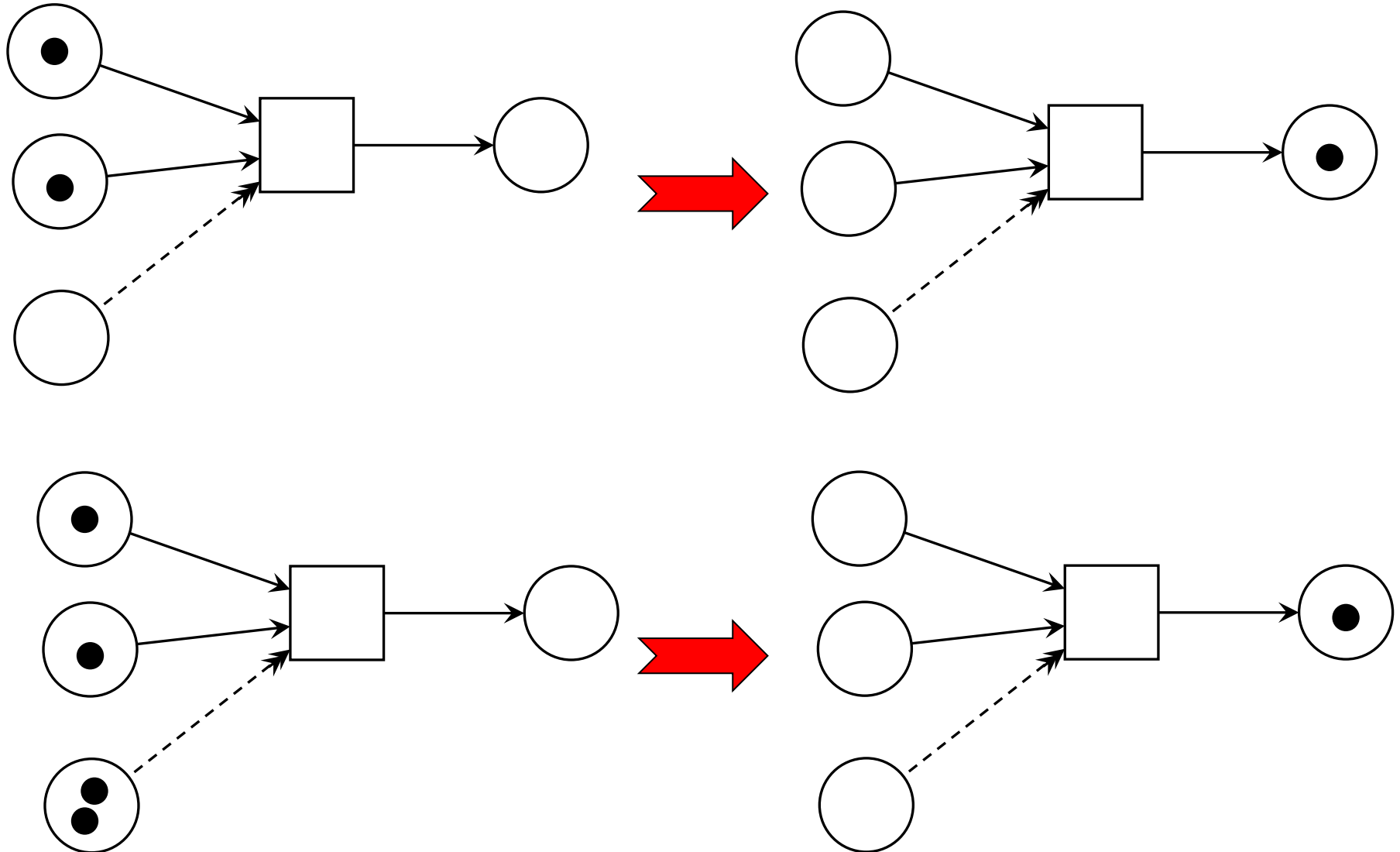

Except for some subtle differences, the concepts for modelling the control aspects of business processes are generally accepted. But there are many different notations for business process and workflows:

- BPMN (Business Process Modeling and Notation)
- EPC (Event-driven Process Chains)
- Activity diagrams
- BPEL
- ...

Activity diagrams are the UML-way of modelling a business processes.

Example: Activity diagrams

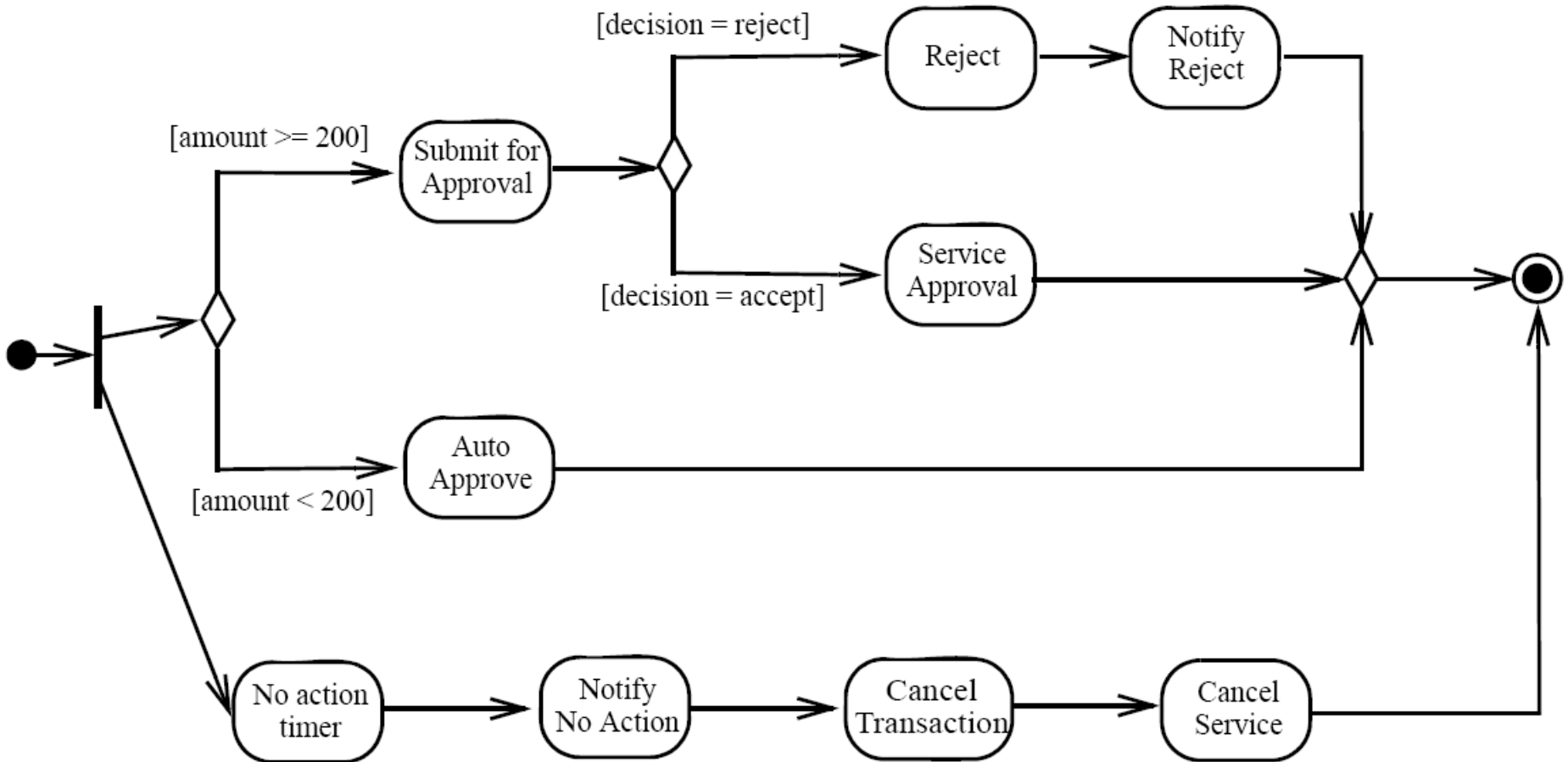

From: OMG Unified Modeling Language (OMG UML), Superstructure, V2.1.2, November 2007, p. 331

Project Presentation

DTU Compute

Department of Applied Mathematics and Computer Science

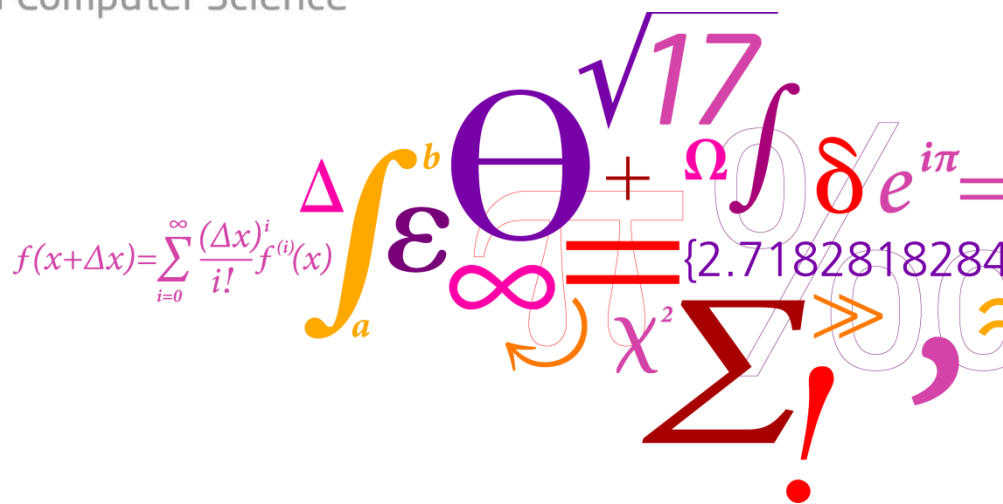

Tutorial 3: Q & A

DTU Compute

Department of Applied Mathematics and Computer Science

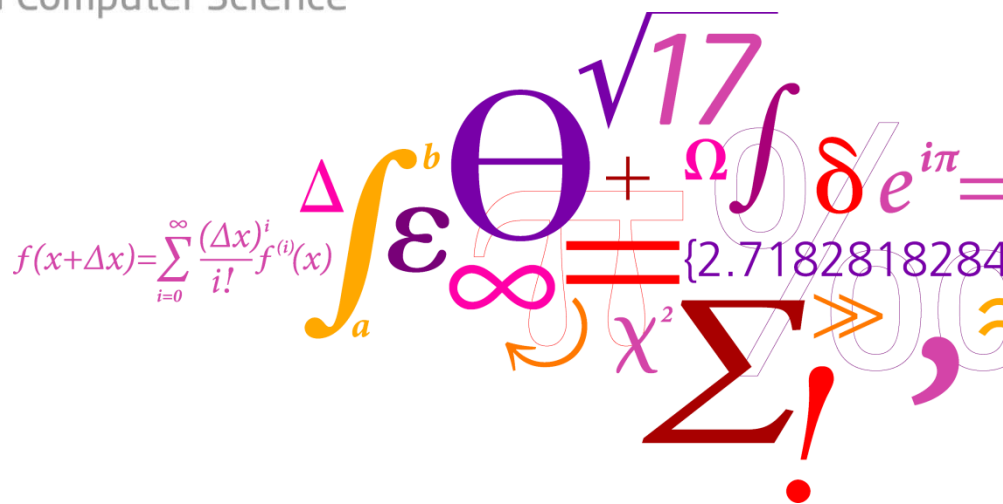

$$f(x+\Delta x) = \sum_{i=0}^{\infty} \frac{(\Delta x)^i}{i!} f^{(i)}(x)$$

$$\int_a^b \varepsilon \Theta + \Omega \int \delta e^{i\pi} = \{2.7182818284\}$$

$$\chi^2 \sum ! >> \infty$$

$$\sqrt{17}$$

$$\infty$$

$$\chi^2$$

$$\sum !$$

$$>>$$

$$\infty$$

Tutorial 4: Discussion Assignment 4

DTU Compute

Department of Applied Mathematics and Computer Science

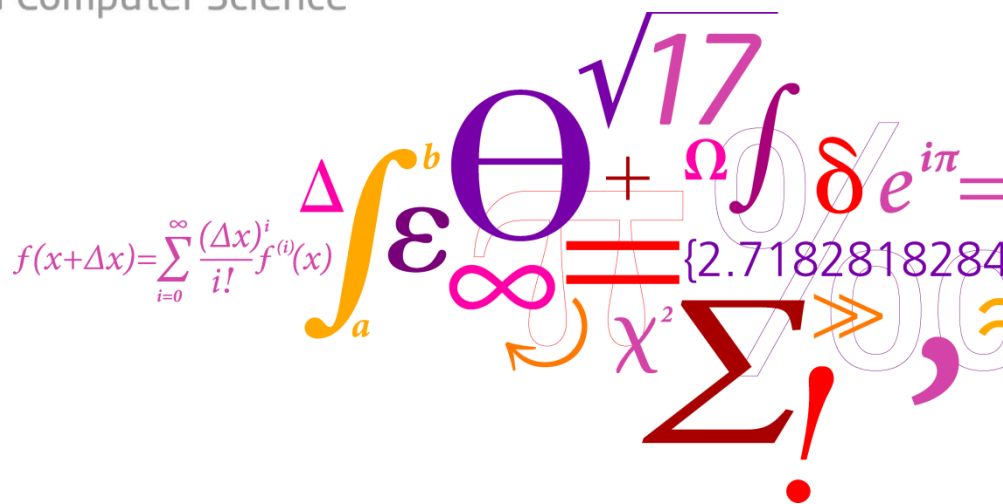
$$f(x+\Delta x) = \sum_{i=0}^{\infty} \frac{(\Delta x)^i}{i!} f^{(i)}(x)$$

A collage of mathematical symbols including the Taylor series formula, integral, infinity, plus, square root, delta, exponential, equals, curly braces, chi squared, sigma, and exclamation mark.