

Reading material

At the lecture we will talk about network flows. For reading material see the webpage.

Exercises

- [w] **Max flow/min cut** Solve exercises KT 7.1 and 7.2.
- [w] **Ford-Fulkersons algorithm** Compute a maximum flow and minimum cut on graph below.

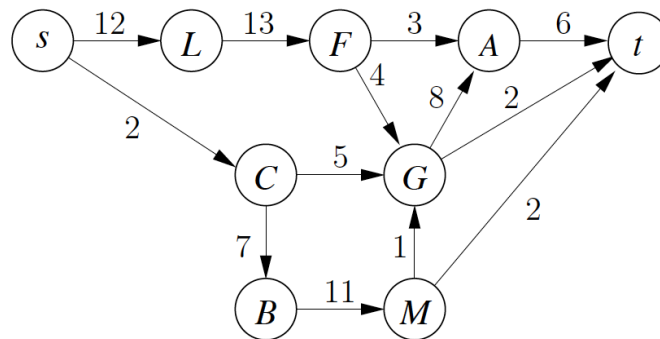

- Properties of maximum flows** Solve exercise KT 7.4.
- Properties of minimum cuts** Solve exercise KT 7.5.
- Zombie breakout (from the Exam 2014)** A zombie breakout has occurred in the country 1D and you have been asked by the prime minister to help find solutions to stop the infection. You are given a map of the country, with coordinates of all cities. There are X infected cities and Y uninfected cities. The map also contains information about all roads between cities. A road goes directly to from one city to another and all roads are directed. There are R roads. A city is reachable from the capital if you can follow one or more roads from the capital to the city. You can assume that the travel time from the capital to any reachable city is no more than a day.
 - Save the capital** The zombies only travel on the roads. The capital is still uninfected and the prime minister wants to know how many roads that must be destroyed to keep the capital uninfected. Give an algorithm to compute the minimum number of roads that has to be destroyed to cut off the capital from the infected cities. Analyze the running time of your algorithm in terms of X , Y , and R . Remember to argue that your algorithm is correct.
 - Distributing the vaccine** Researchers in the center in the capital have found a vaccine. To get the vaccine to the people in the uninfected cities we need to send 10 doctors to each uninfected city. The doctors can only travel on the roads. They can go through infected cities but at most 50 doctors can go through each infected city per day. Give an algorithm to decide whether we can get the vaccine out to all uninfected cities in one day. Analyze the running time of your algorithm in terms of X , Y , and R . Remember to argue that your algorithm is correct.
- CSES** Solve the exercise Download Speed (under Graph Algorithms): <https://cses.fi/problemset/task/1694> First give an algorithm and analyse its correctness and running time. Then implement it afterwards.

Puzzle of the week: Four Coins You have to win a game against the hangman. Before the game starts you are blindfolded. There are four coins placed on a square table, one coin at each corner. The initial configuration of the coins is chosen by the hangman, arbitrarily and unknown to you. Your goal is to have all four coins heads up. In each move you can select any subsets of the four coins, which are then flipped simultaneously by the hangman. After your move, if all four coins are heads up, you win. If not, the hangman may rotate the table by an amount of his choice (90, 180, 270, or 360 degrees). If you don't manage to have all four coins heads up in 20 moves or less, you lose and the hangman executes his job. What's your strategy?